



US006674842B2

(12) **United States Patent**  
**Weinman, Jr.**

(10) **Patent No.:** **US 6,674,842 B2**  
(45) **Date of Patent:** **\*Jan. 6, 2004**

(54) **MULTI-LINE TELEPHONE WITH INPUT/  
OUTPUT MIXING AND AUDIO CONTROL**

- (75) Inventor: **Joseph B. Weinman, Jr.**, Basking Ridge, NJ (US)
- (73) Assignee: **AT&T Corp.**, New York, NY (US)
- (\*) Notice: Subject to any disclaimer, the term of this patent is extended or adjusted under 35 U.S.C. 154(b) by 0 days.

This patent is subject to a terminal disclaimer.

(21) Appl. No.: **10/171,903**

(22) Filed: **Jun. 14, 2002**

(65) **Prior Publication Data**

US 2002/0150220 A1 Oct. 17, 2002

**Related U.S. Application Data**

- (62) Division of application No. 09/268,538, filed on Mar. 15, 1999.
- (60) Provisional application No. 60/114,555, filed on Dec. 31, 1998.
- (51) **Int. Cl.**<sup>7</sup> ..... **H04M 1/64**; H04M 11/00; H04M 17/00
- (52) **U.S. Cl.** ..... **379/88.13**; 379/88.17; 379/93.35; 379/156; 379/157; 379/202.01; 379/207.01; 379/102.03
- (58) **Field of Search** ..... 379/88.13, 88.17, 379/88.18, 93.09, 93.35, 100.15, 100.02, 142.08, 156, 157, 158, 177, 202.01, 207.01, 215.01, 102.03, 101.01

(56) **References Cited**

U.S. PATENT DOCUMENTS

- 5,533,110 A \* 7/1996 Pinard et al. .... 379/201
- 6,188,755 B1 \* 2/2001 Hayashi et al. .... 379/156
- 6,453,022 B1 \* 9/2002 Weinman, Jr. .... 379/88.13

\* cited by examiner

*Primary Examiner*—Allan Hoosain

(57) **ABSTRACT**

The present invention is a method and apparatus for selectively controlling the interconnectivity of two or more active telephone lines and/or one or more audio characteristics of each of the active telephone lines during a multi-line call. A bridge or a call connection control may be implemented to provide selective call connection for each active telephone call. The user may thereby control the interconnectivity of each party to the user and to the other parties to the conference or multi-line call. An audio controller may also be implemented within a multi-line telephone or at a telephony switch. The call connection control or the volume control may be implemented within the telephone network such as a switch or locally at the telephone unit. The user may provide the desired interconnectivity or volume parameters for the multi party call using a user interface. Optionally, the audio controller may process the audio signals of the conferenced telephone lines and intelligently adjust the audio characteristics of the audio signals.

**16 Claims, 12 Drawing Sheets**

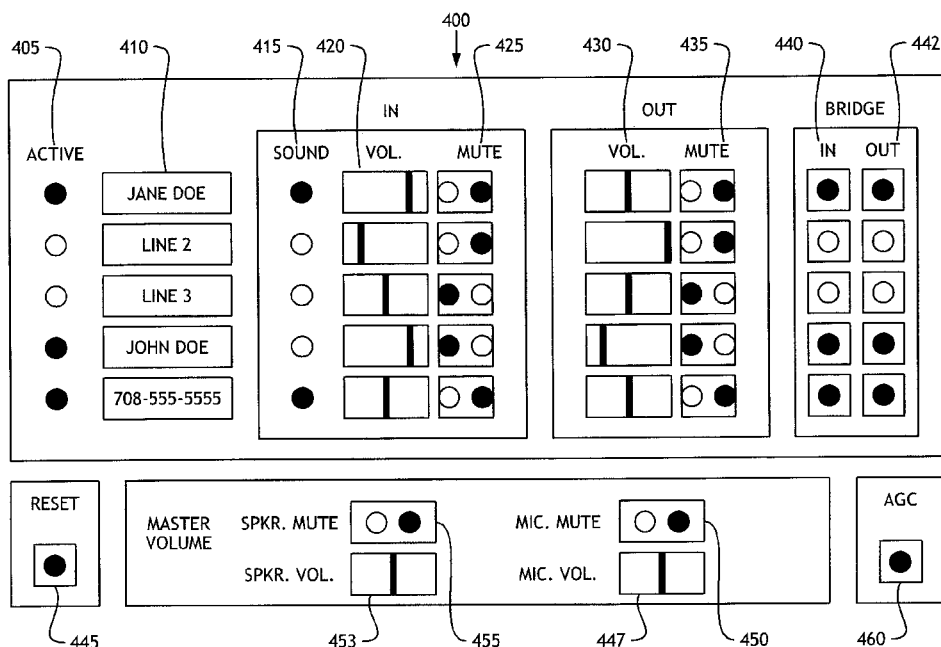

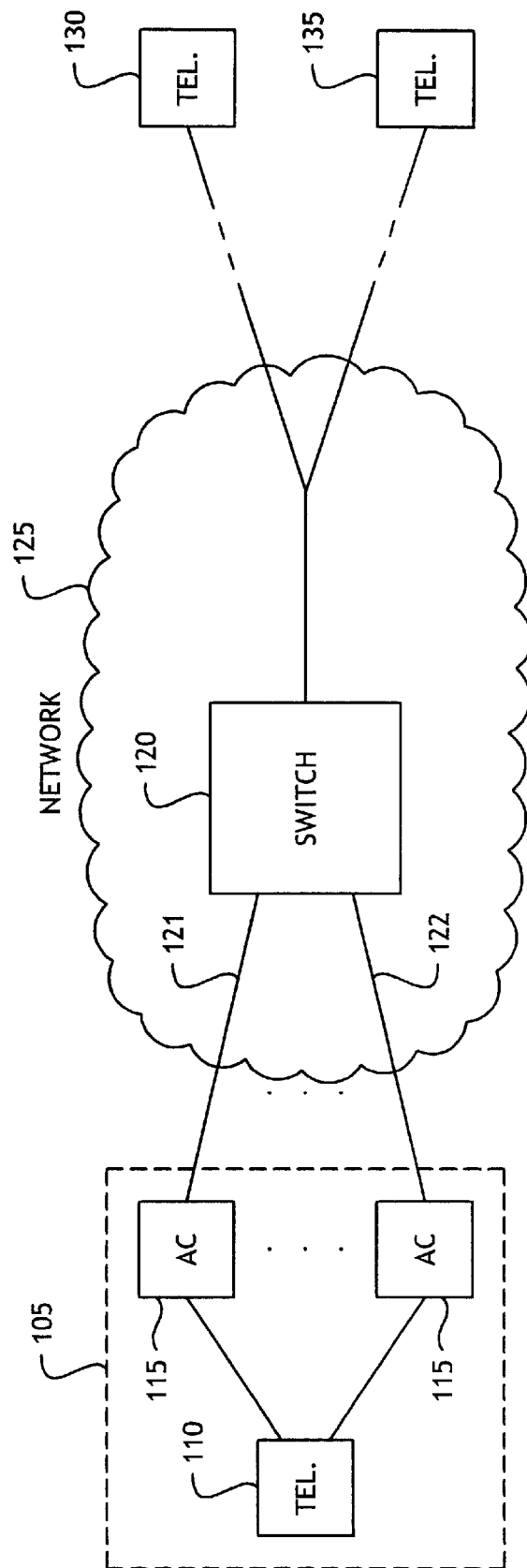

Fig. 1

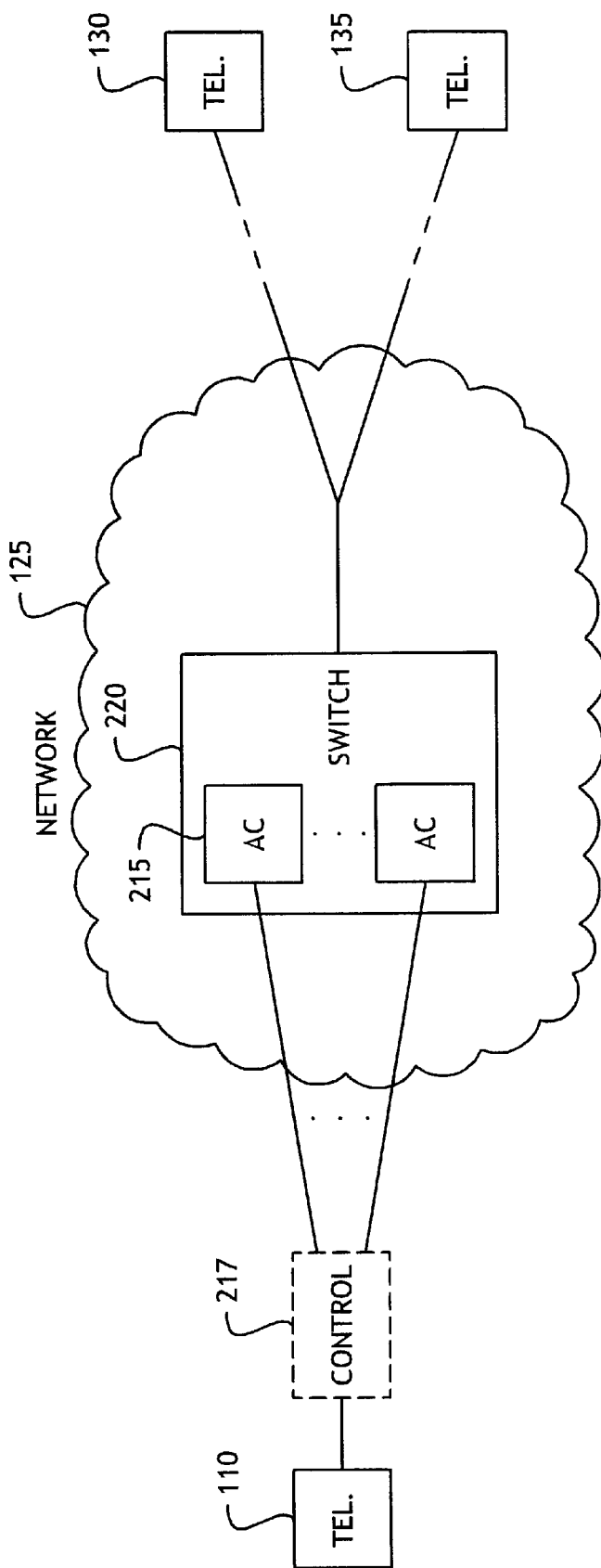

Fig. 2

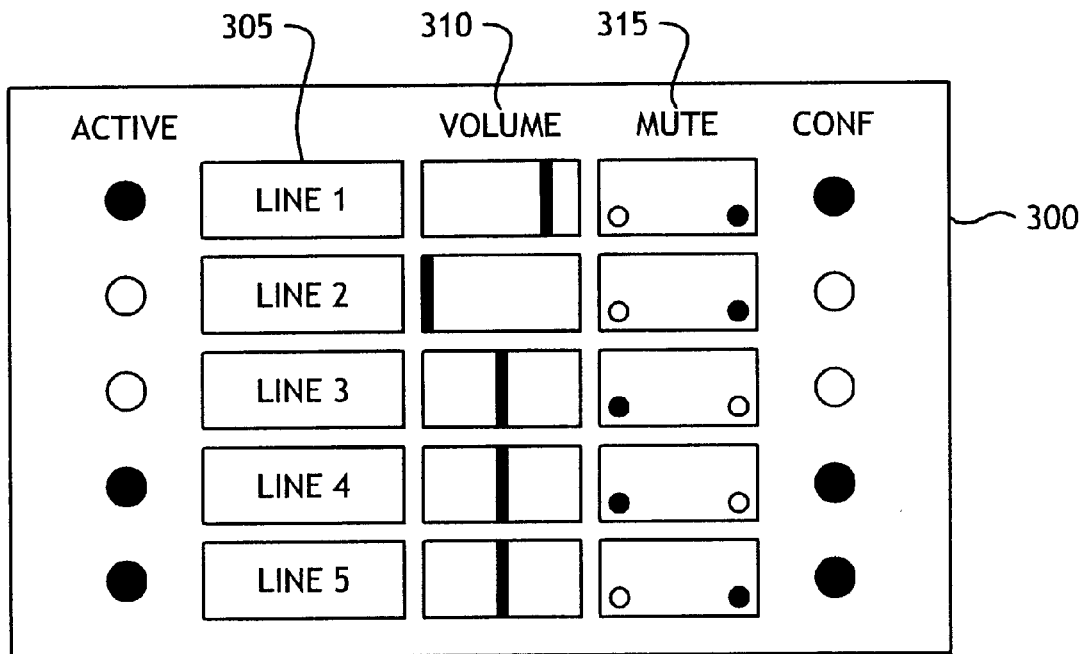

Fig. 3

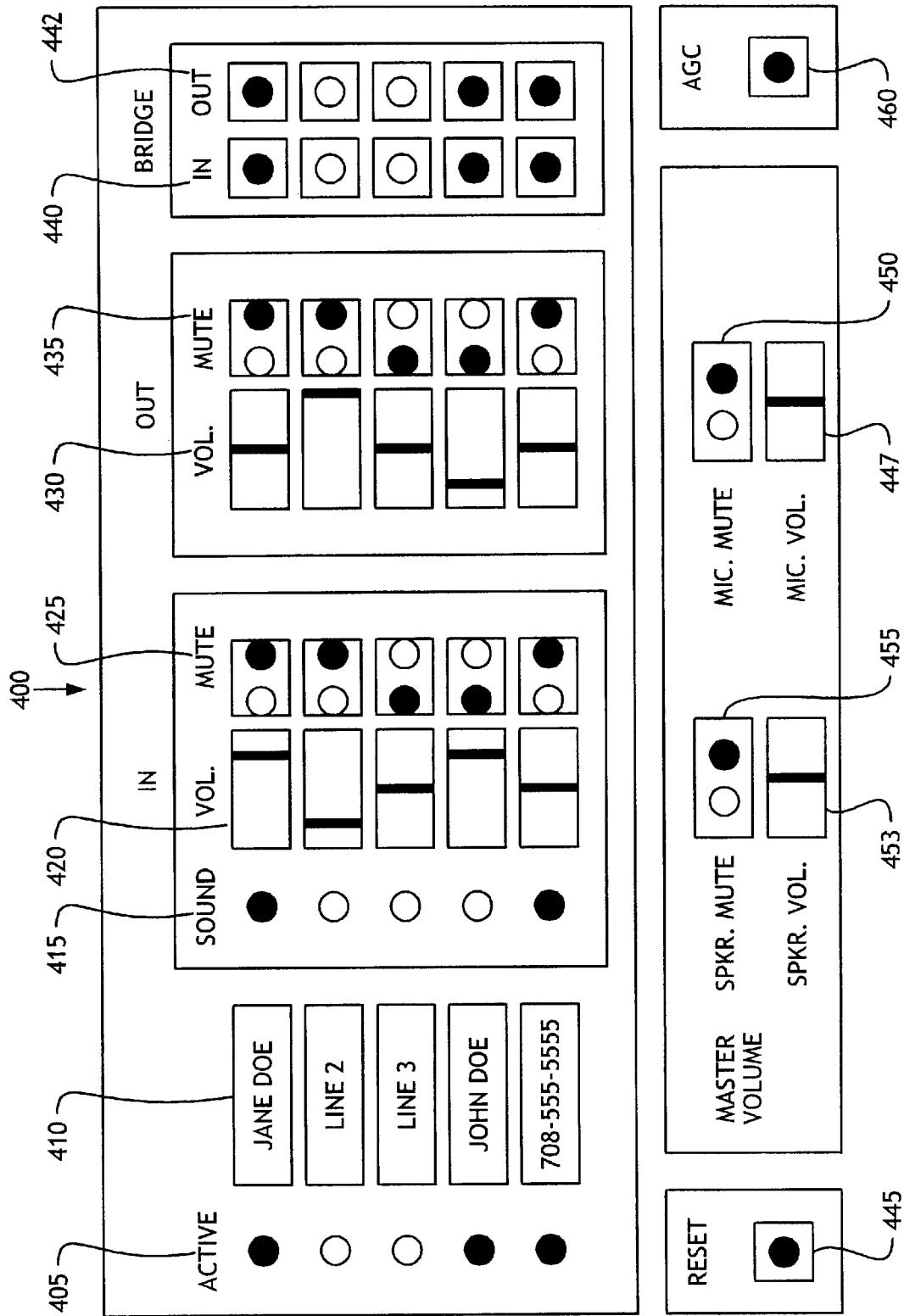

Fig. 4

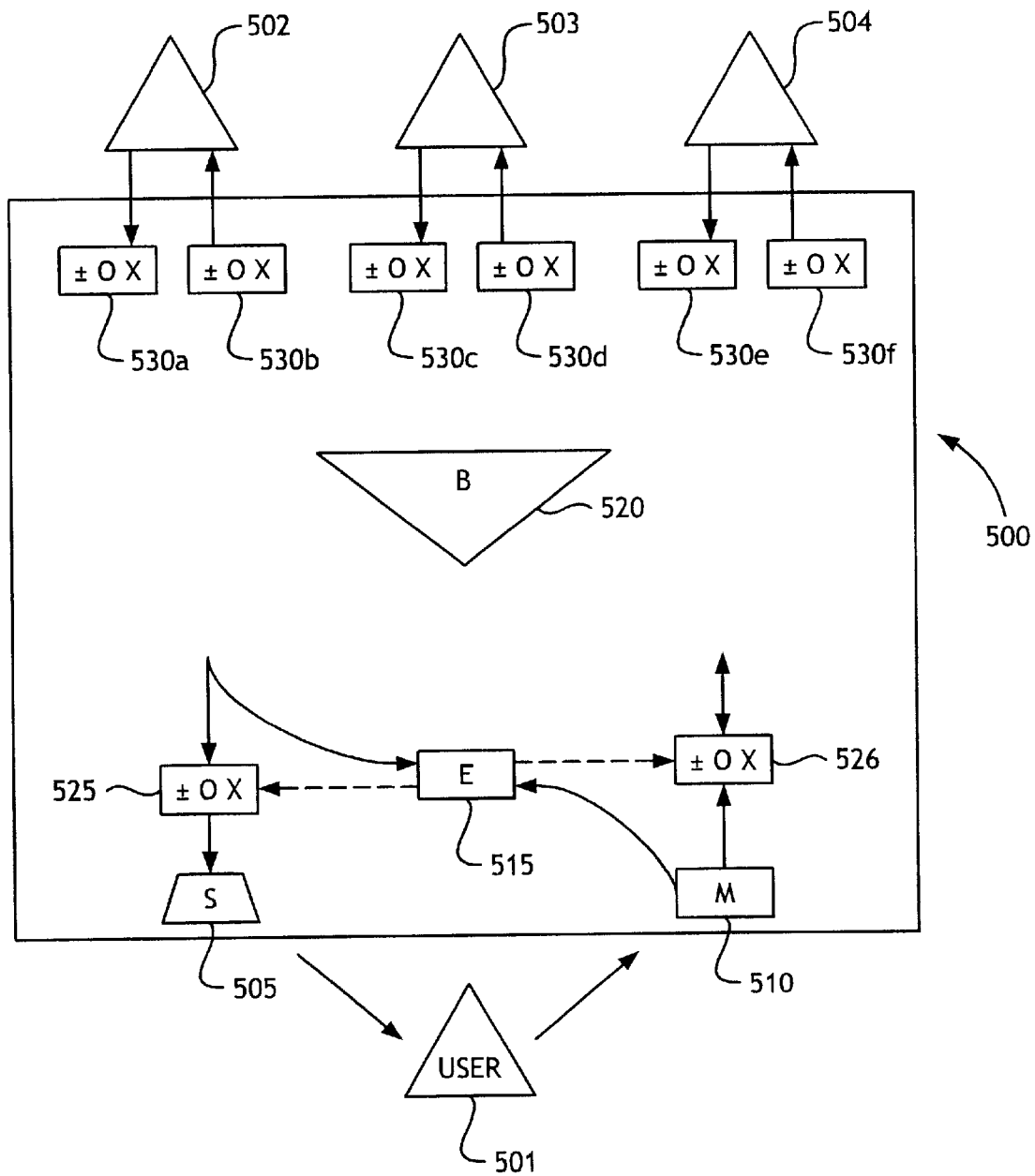

Fig. 5

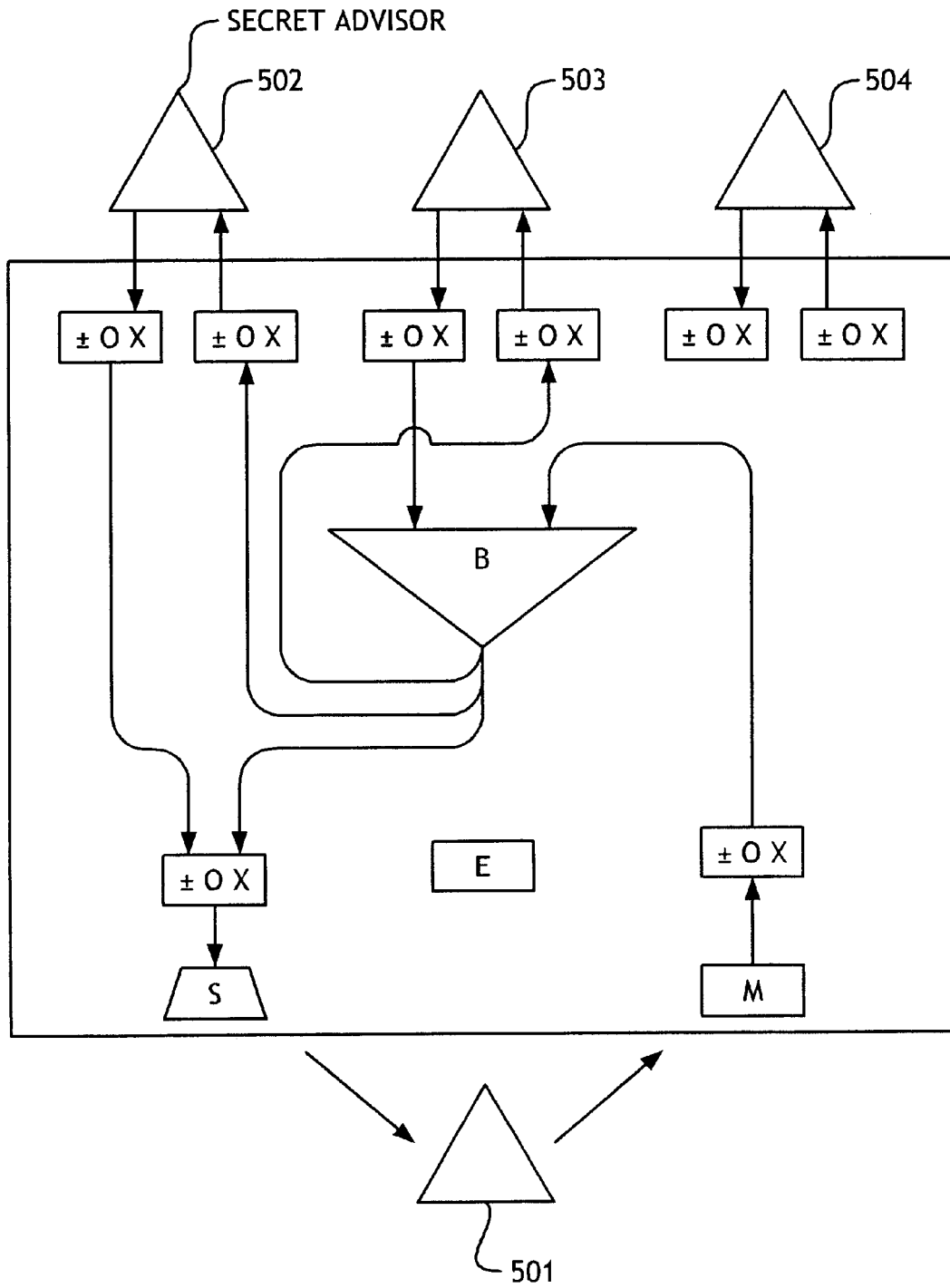

Fig. 6

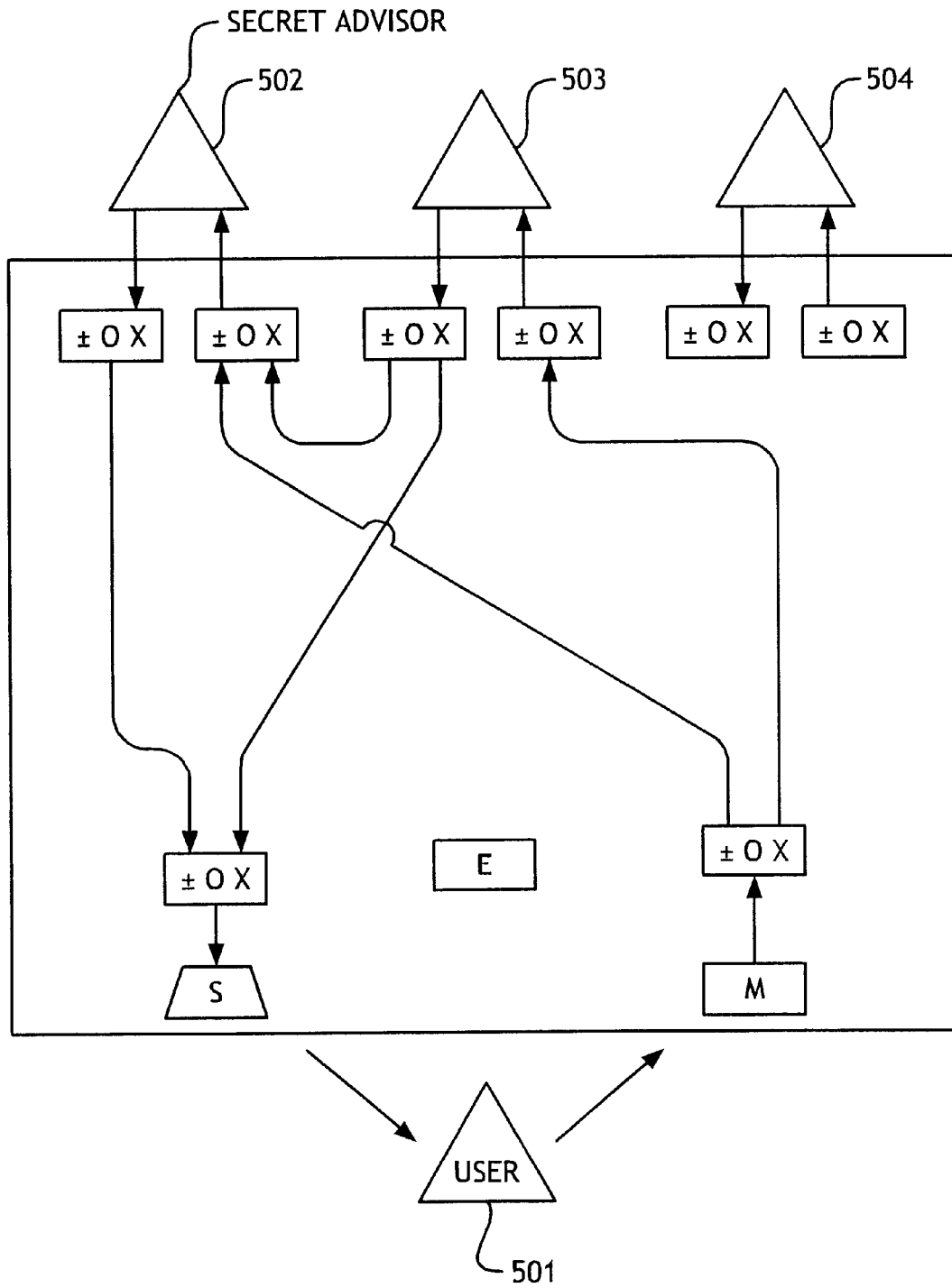

Fig. 7



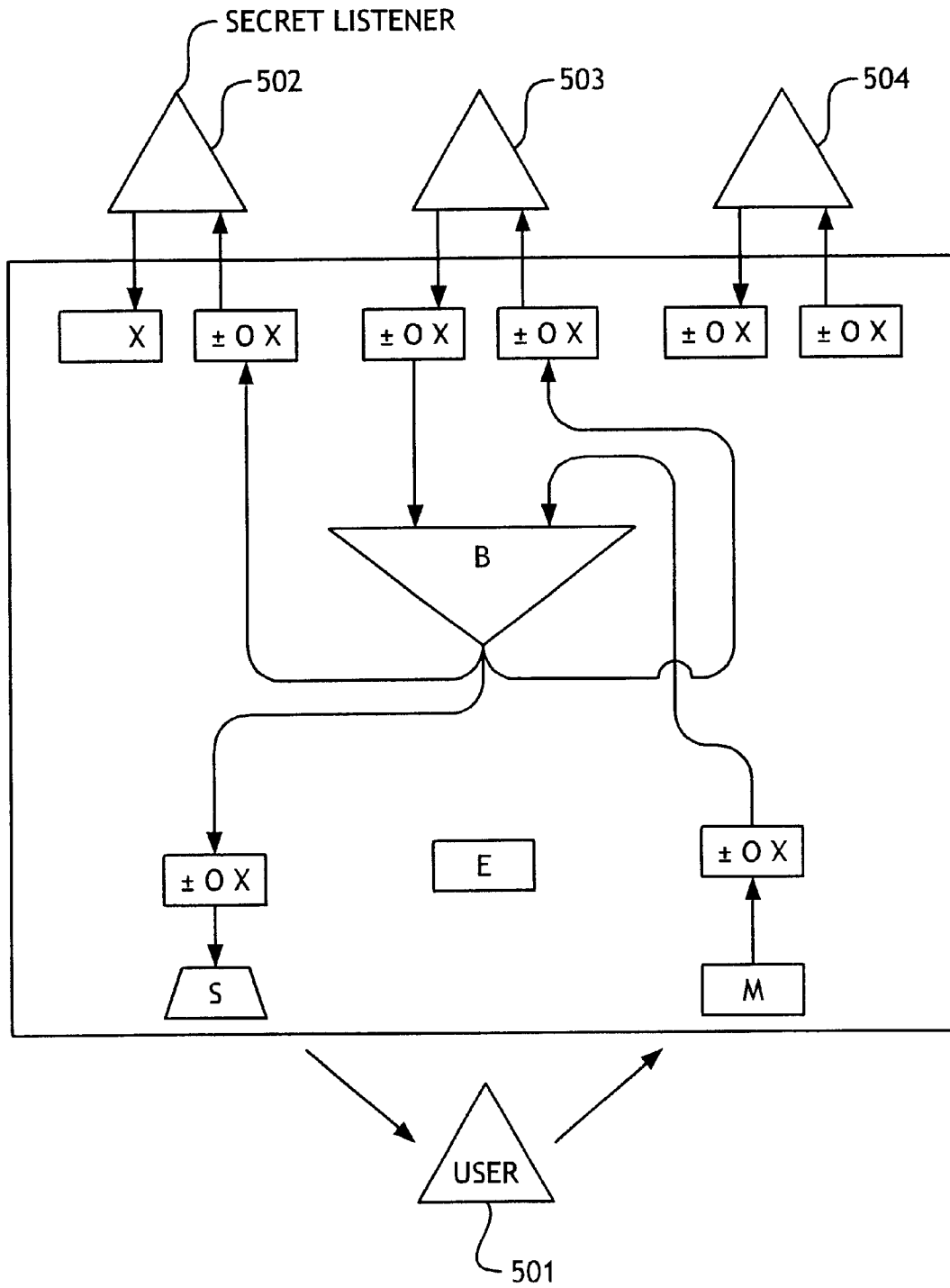

Fig. 8

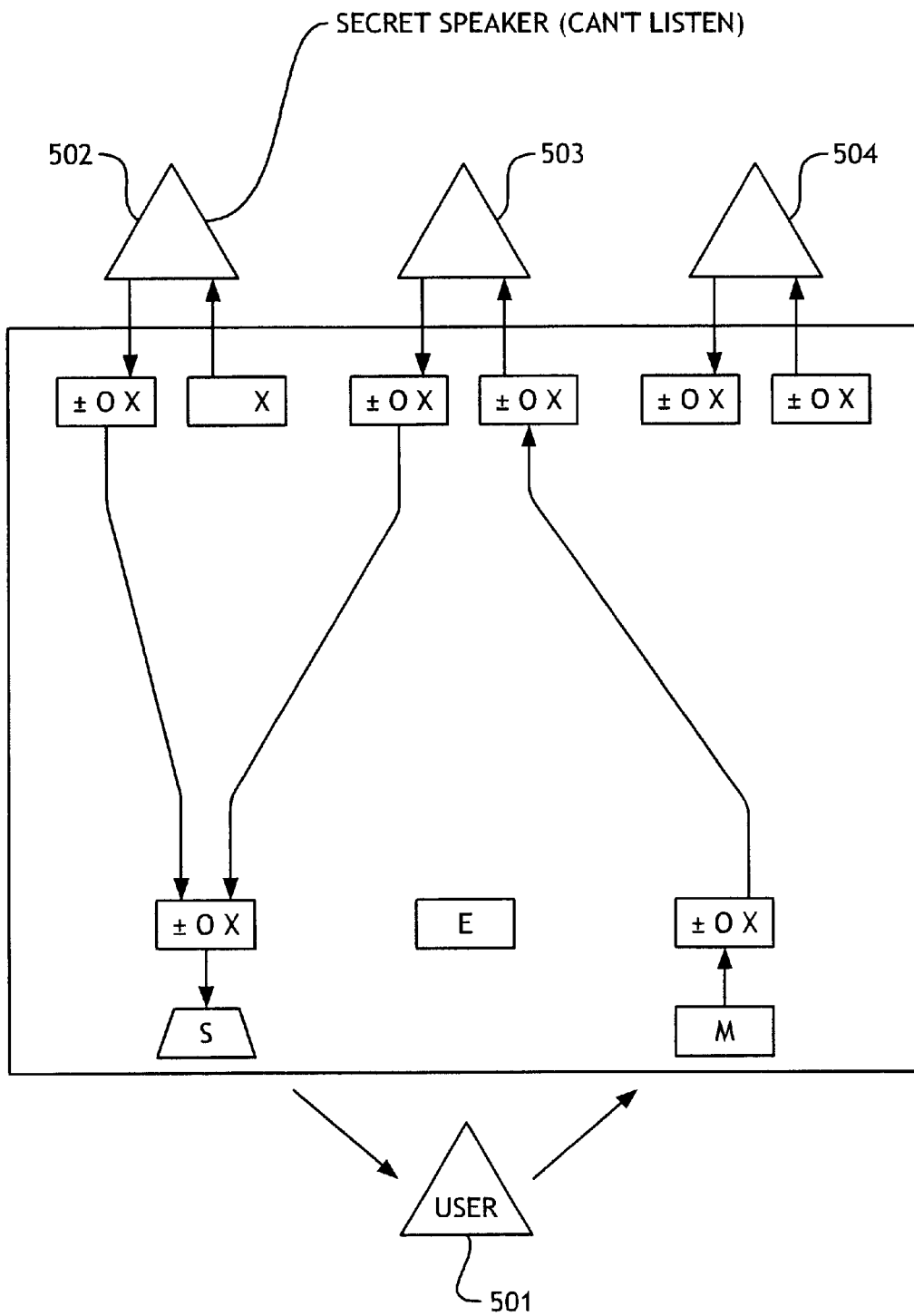

Fig. 9

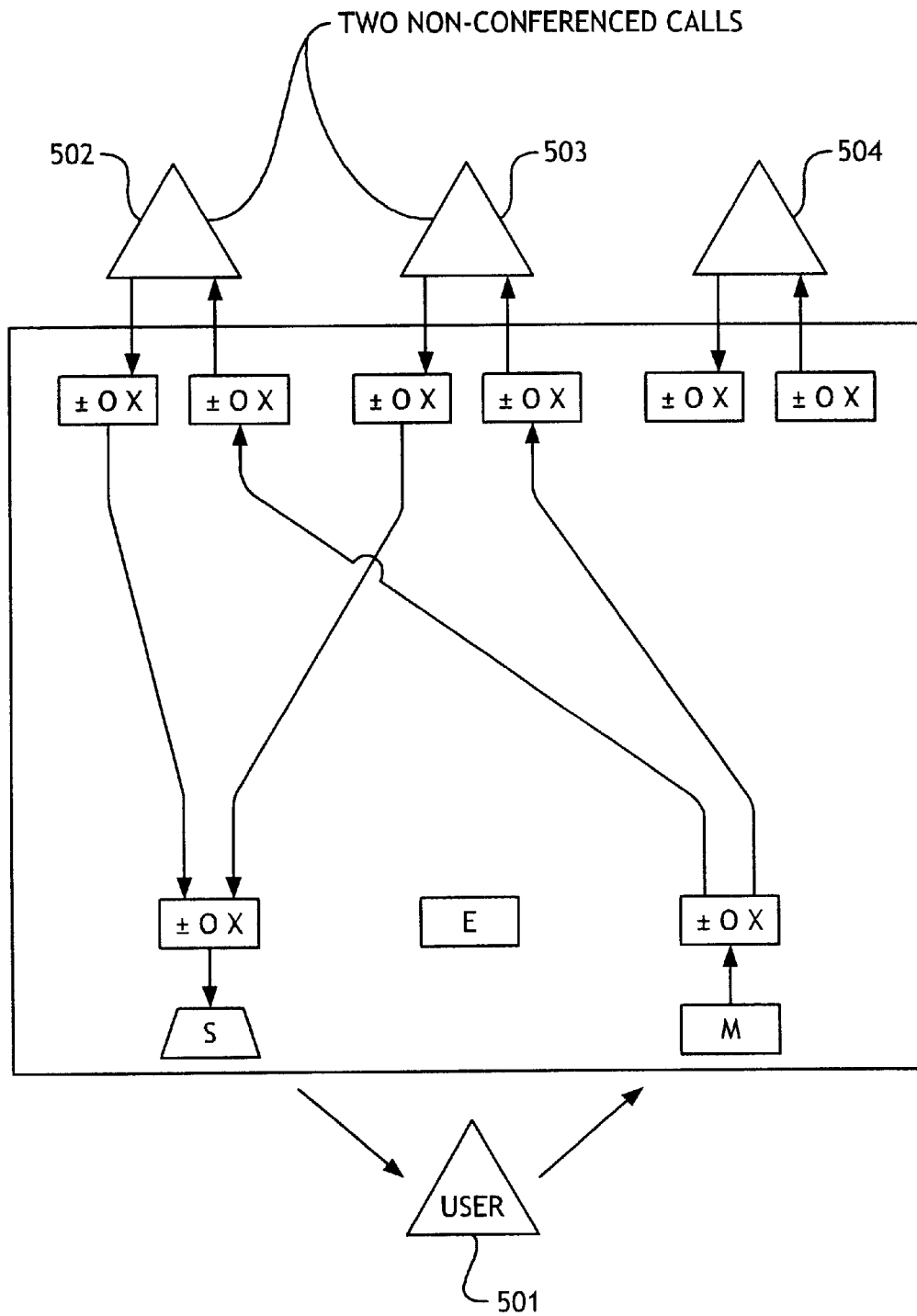

Fig. 10

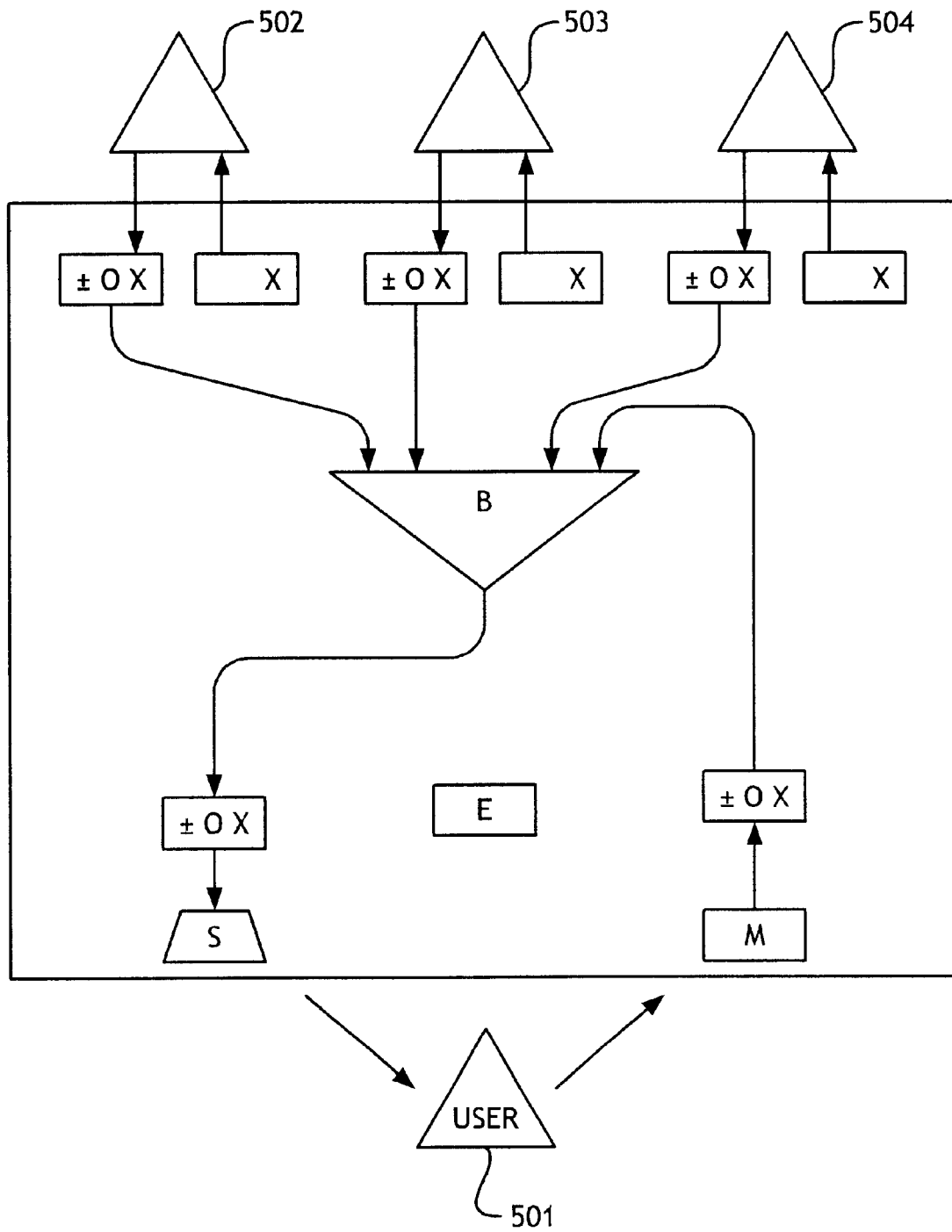

Fig. 11

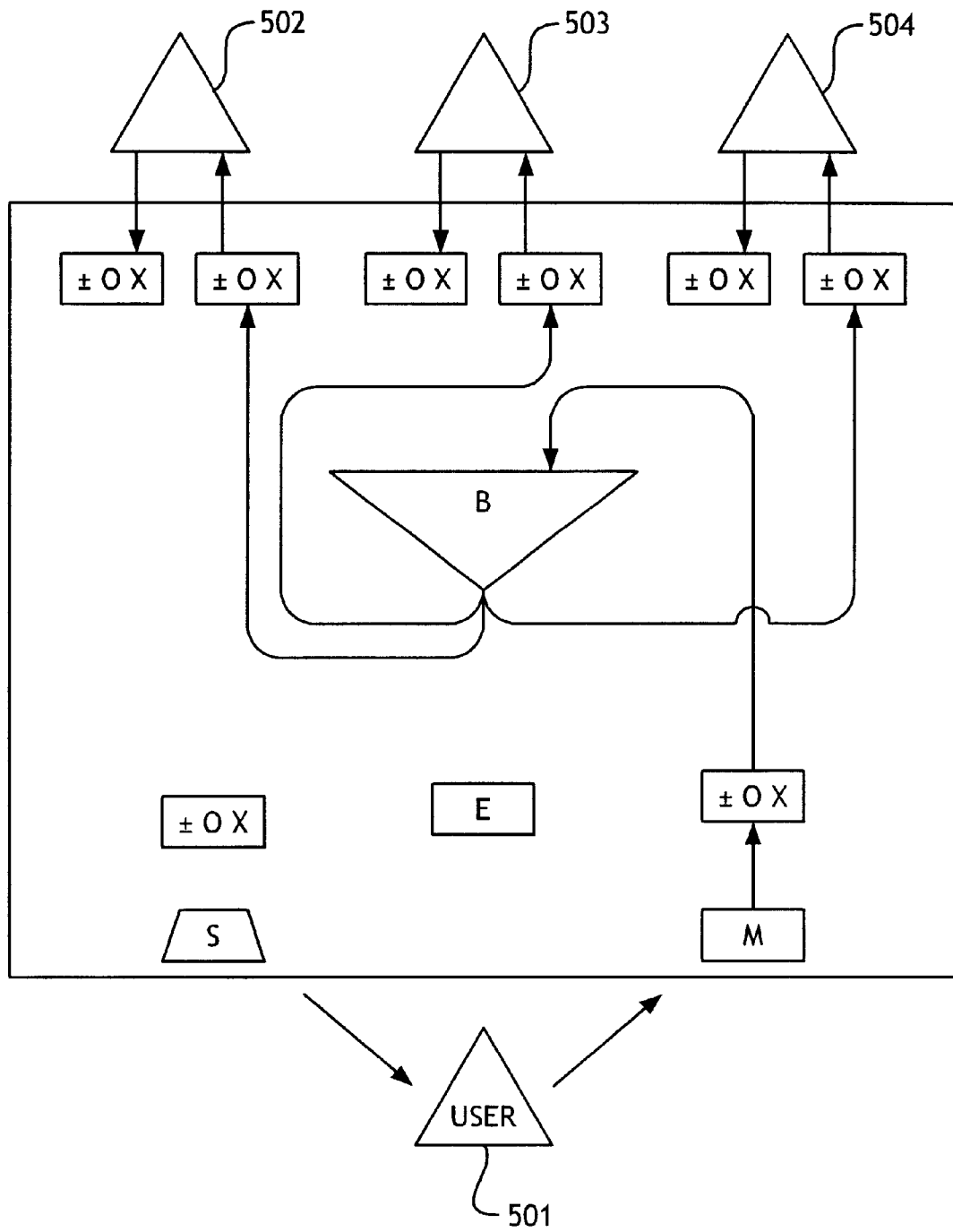

Fig. 12

## MULTI-LINE TELEPHONE WITH INPUT/ OUTPUT MIXING AND AUDIO CONTROL

This patent application is a divisional of U.S. patent application Ser. No. 09/268,538, filed Mar. 15, 1999, for which priority is claimed. The parent application is incorporated herein by reference in its entirety. The parent application claims the benefit of U.S. Provisional Application No. 60/114,555 filed on Dec. 31, 1998.

### FIELD OF THE INVENTION

The present invention relates to telephone systems providing multiple party calling and more particularly to a multi-line calling telephone system capable of selectively controlling the interconnectivity and audio characteristics of each individual active telephone line.

### BACKGROUND OF THE INVENTION

Conference and multi-person calling have become increasingly popular and common calling techniques for businesses as well as individual subscribers. These multi-line calling techniques allow multiple callers to be connected to each other thereby allowing the callers to communicate with each other. The user may couple two or more telephone lines such that the user and the parties associated with the respective telephone lines may communicate with each other in a conference call. Alternatively, the user may place multiple calls and communicate with each of the called parties without allowing the called parties to communicate with each other. A telephone party may be conferenced or simultaneously coupled to multiple parties within a multi-line telephone or even an ordinary telephone. In a multi-line telephone, a plurality of telephone lines may be coupled to a single multi-line telephone unit. The user may select the particular telephone line from which to place a call or the particular line to answer an incoming call; alternatively, the multi-line telephone may automatically select the lines.

The multiple party calling concept may also be implemented within multi-media communication systems. For example, U.S. Pat. No. 5,195,086 discloses a multiple call control method in a multimedia conferencing system where each call may comprise one or more channels. Such systems allow multiple parties to communicate over voice, video and data lines.

These conferencing and multi-line systems, however, are limiting in a variety of respects. For instance, these systems have a limited ability to control the interconnectivity between the parties in a multi-party call. As a result, these systems cannot handle a number of functions that the calling party may seek in a multi-line telephone system. For example, in the case where a calling party is conferenced with one or more conferenced parties, the calling party may seek to conference in a secret advisor to the call such that the secret advisor may hear the entire conversation, and advise the calling party without the secret advisor being heard by the other conferenced parties. Alternatively, if the calling party is on hold by the first called party, the calling party may seek to place other calls while on hold while not having the two calls conferenced together, yet continue to listen to the held call. The calling party may wish to independently monitor the line in which he/she is on hold while engaging in a discussion with the other called parties. In yet another example, the calling party may seek to make a plurality of non-conferenced calls and broadcast one or more messages, or simultaneously listen to all of the parties. Present systems are unable to provide the user with these and other such finer

call control features that can greatly enhance the functionality of the system

The conferencing and multi-line systems of the prior art are also limiting in that they are unable to control one or more audio characteristics of each individual line. Often, during a conference call, one party is calling through a bad telephone connection or the party is using a weak telephone receiver. This affects the conference call as this party is barely heard by the other parties to the conference call. Further, in the case of a half-duplex conferencing system, the party having the bad connection may not be able to interrupt when others are talking or even if there is background noise. Alternatively, where a party's line has a lot of noise (such as in the case where the party is using a cellular phone), it may be desirable to reduce the volume or noise level from that party. In other call conferencing situations, the user may desire that the volume of one line be different than that of another line and also to re-adjust the connection mode. For example, in the case where the user is on hold on a first line and that line is playing background music, the calling party may wish to decrease the volume of that line while he/she continues discussions with another conferenced party on a second line. When the party from the first line returns, the calling party may then wish to re-adjust the volume of the first line relative to the second line. Telephone sets generally have volume control but this control merely adjusts the overall volume output from the telephone speaker. Such telephone sets are incapable of selectively distinguishing between the telephone lines to control the relative volume of each individual line or other audio characteristics of the line such as noise, bass, treble, etc.

Consequently, there remains a need in the art to provide a multi-line telephone system capable of providing enhanced interconnectivity control and selective control of one or more audio characteristics for each of the active telephone lines.

### SUMMARY OF THE INVENTION

The present invention is directed to solving these and other problems and disadvantages of the prior art. The present invention is a method and apparatus for selectively controlling the interconnectivity and one or more audio characteristics of one or more active telephone lines during a conference or multi-line call. A bridge or a call connection control may be implemented to provide selective call connection for each telephone call. The user may thereby control the interconnectivity of each party to the user and to the other parties to the conference or multi-line call. An audio controller may also be implemented within a multi-line telephone or at a telephony switch. The call connection control or the audio control may be implemented within the telephone network such as a switch or locally at the telephone unit. The user may provide the desired interconnectivity or audio parameters for the multi party call using a user interface. Optionally, the audio controller may process the audio signals of the conferenced telephone lines and intelligently adjust one or more audio characteristics of the audio signals.

Further details and features of the present invention may be understood from a careful reading of the detailed description thereof which follows.

### BRIEF DESCRIPTION OF THE DRAWINGS

FIG. 1 is a schematic diagram of a multi-line telephone system in accordance with a preferred embodiment of the present invention as implemented within a communications network;

3

FIG. 2 is a schematic diagram of a multi-line telephone system implemented within a communications network in accordance with another preferred embodiment of the present invention;

FIG. 3 shows a preferred embodiment of a user interface of a multi-line telephone system in accordance with the present invention;

FIG. 4 shows another preferred embodiment of a user interface of a multi-line telephone system in accordance with the present invention;

FIG. 5 is a schematic block diagram of a telephone system in accordance with the present invention; and

FIGS. 6-12 are illustrations of exemplary multi-line call connections that may be made in accordance with the present invention.

#### DETAILED DESCRIPTION

FIG. 1 is a schematic diagram of a multi-line telephone system **105** in accordance with a preferred embodiment of the present invention as implemented within a communications network. The multi-line telephone system **105** includes a multi-line telephone **110** coupled to one or more telephone lines **121** and **122**. The multi-line telephone **110** may have two or more telephone lines which may be separate telephone lines or may be fewer lines that are multiplexed to provide functionality for a greater number of telephone lines. The multi-line telephone system further includes an audio controller **115** (discussed in further detail herein) for each of the telephone lines **121** and **122** associated with multi-line telephone **110**. Multi-line telephone system **105** is coupled to a central office **120** of a standard public telephony network **125**. Other or additional switching systems may be utilized to couple multi-line telephone **110** to network **125**, including, but not limited to, a Private Branch Exchange (PBX). Multi-line telephone system **105** is capable of placing calls to or receiving calls from two or more calling parties at telephones **130** and **135** and conferencing the two or more calls. A conference call allows a user at multi-line telephone **110** and parties at telephone **130** and **135** to communicate with each other. Typically, the three conferenced parties communicate with each other by voice or audio signals. Multi-line telephone system **105** may be implemented within a multi-media system capable of audio, video and data communications. In this case, a conference call allows the conferenced parties to communicate by audio, video and data signals.

Advantageously, in accordance with this embodiment of the present invention, multi-line telephone system **105** includes one or more audio controllers **115** that allow the user to selectively adjust one or more characteristics of the audio signal received and transmitted by multi-line telephone **110** over one or more of the telephone lines **121** and **122**. Audio controller **115** independently or collectively adjusts parameters of the incoming and outgoing signal of the telephone line associated with the particular audio controller **115**. Audio controller **115** may take the form of any device including, but not limited to, electrical, mechanical, optical or any the amplitude of the incoming voice signal delivered to multi-line telephone by that telephone line. For example, audio controller **115** may include an attenuator, an electrical filter and/or a multiplier. Audio controller **115** may control any number of audio characteristics including, for example and without limitation, peak volume, average volume, average dB, noise level, bass and treble. Those skilled in the art will appreciate that audio controller **115** may incorporate any number of techniques known in the art to adjust any of these and other audio characteristics.

4

Multi-line telephone system **105** may incorporate an audio controller **115** for each telephone line, as shown in FIG. 1, and/or may implement a single master audio controller **115** capable of controlling the voice signal amplitude of all associated telephone lines. Under the latter embodiment, single audio controller **115** may include a switch to select the telephone line for which to control.

FIG. 2 is a schematic diagram of a multi-line telephone system implemented within a communications network in accordance with another preferred embodiment of the present invention. Under this embodiment, a central office or switch **220** includes one or more audio controllers **215**. Under this embodiment, audio controller **215** may be associated with an individual telephone line or may control audio signal amplitudes of a plurality of telephone lines. Audio controller **115** is preferably still controlled by the telephone customer. Advantageously under this embodiment, a multi-line telephone having the hardware to practice the present invention would not be required, but rather a standard multi-line telephone would suffice. The audio characteristics of each telephone line may be controlled by the user providing control signals to switch **220**. For example, the user may use the telephone keypad, or voice instructions, to provide instructions to increase or decrease the relative volume of any given telephone line. Alternatively, a local controller **217** having a user interface may be provided to generate control signals for audio controller **215**. Local controller **217** may be a separate component coupled between multi-line telephone **110** and switch **220** and may optionally be installed within a customer's proprietary network. In yet another embodiment, local controller **217** may be part of multi-line telephone **110**. ISDN, SS7, proprietary or any other signaling technique may be used to deliver control signals from multi-line telephone **110** or local controller **217** to audio controller **215** of switch **220**.

FIG. 4 shows an exemplary user interface **400** of a multi-line telephone system in accordance with one preferred embodiment of the present invention. As shown in this figure, interface **400** is capable of connecting to five telephone lines and capable of selectively establishing the connectivity and/or audio characteristics of each line. Interface **400** illustrates a user interface for achieving the functionality of the present invention and includes a number of controls that are grouped in columns by functionality and in rows according to the telephone line. Interface **400** includes a telephone line column **410** indicating the telephone line. Telephone line column **410** may have a display for each telephone line to identify the party or telephone number associated with that line. Such a display may be utilized in conjunction with a callerID subscriber service such as is commonly available. An activity column **405** having a light emitting diode (LED)-type device in association with each telephone line may be used to indicate whether a particular telephone line is active. Interface **400** of FIG. 4 includes another group of columns to selectively monitor and control the signaling received by the user from each of the parties. A sound column **415** having a light emitting diode (LED)-type device in association with each telephone line may be used to indicate whether the party associated with that telephone line is speaking. Sound column **415** may also be a bar display and/or may have some memory capability to display historical sound characteristics, similar to the horizontal bar display that is found in audio equipment such as stereos.

Advantageously, this memory capability allows the user to identify the telephone line from which an audio signal originated in case the user happened to look away from the

user interface while the audio signal was being delivered. This feature also allows the user to identify the source of the audio signal in the event that the user is monitoring a plurality of telephone lines. An input audio signal column **420** similar to that of FIG. 3 (discussed below) may be used to selectively adjust the audio characteristic(s) of each of the incoming telephone lines. Audio control is preferably implemented with an electronic control system such that the reset functionality (discussed herein) may be utilized. Further, an input mute column **425** is shown to prevent the signaling from any of the incoming callers from being received by the user. The user may mute a party by depressing the mute button corresponding to the party. When a muted party is talking the sound indicator of sound column **415** would light up such that the user is informed that the muted party is speaking. The user may then start receiving signaling from the muted party by depressing again the mute button corresponding to the muted party.

Interface **400** also includes another group of columns to selectively control the output signaling to each of the parties. An output mute column **435** is provided to selectively prevent any signaling to be sent to the corresponding party to the telephone call. Similarly, an output audio signal column **430** selectively adjusts the audio parameters of the signaling to be delivered to the corresponding party.

A bridge input column **440** is utilized to allow the user to control whether the output of the corresponding party is delivered to the user via a bridge. If a bridge is not used (preferably the default), the output signal from the corresponding party may be delivered directly to the user. Otherwise, the output signal is delivered to the bridge which combines the signal with the other received signals. A bridge output column **442** is utilized to control whether the output from the bridge is to be delivered to the corresponding party. If the bridge is not used, the signal from the user is delivered directly to the corresponding party. Otherwise, the corresponding party receives the output signal from the bridge: As preferred, the user may simultaneously engage in a bridged call as well as a non-bridged call. Bridging is discussed in further detail below. User interface **400** also includes a group of interfaces to control various overall parameters of the telephone call. A reset button **445** may be utilized to reset the parameters adjusted in columns **415-435** and buttons **450-460** to their respective default values. Interface also includes a group of master controls. A master speaker mute control **455** and speaker volume control **453** may be utilized to mute or adjust the volume of the overall signal output from the telephone speaker. Further, a master microphone mute control **450** and microphone volume control **447** may be utilized to mute or adjust the volume of the overall signal output from the telephone to each of the parties to the call. Advantageously, the user may mute or adjust volume without interrupting the settings of each telephone line. An automatic gain control (AGC) **460** may be utilized to automatically adjust the relative volumes of each of the incoming and outgoing signals.

It is appreciated that any number of user interfaces may be utilized to practice the present invention. For example, in the case where more than one bridge is implemented, a user interface in the form of a matrix may be implemented identifying the telephone lines associated with each bridge. The columns may represent each bridge and the rows may reflect the telephone lines. Other variations of the matrix may exist such as for example, where the columns represent input lines and the rows represent output lines. Alternatively, the user interface may allow the user to select the bridge to display as to which lines are coupled to that bridge.

Advantageously, this embodiment of FIG. 4 provides the user with interconnectivity control for each active telephone line of a multi-line call. The features of this embodiment of the present invention may be conceptualized by FIG. 5, which is a schematic illustration of an overall telephone system connecting a user and one or more calling parties. Telephone system **500** couples a user **501** to one or more parties **502-504**. The system **500** has a speaker **505** and microphone **510** coupled to user **501** and controlled by master audio controllers **525** and **526** (elements **447-455** of FIG. 4) respectively. Controller **525** mixes all lines of bridged calls and/or non-bridged calls. Controller **526** distributes the audio output to the bridges and/or to each of the non-bridged calls. An echo feedback canceler **515** is preferably coupled to audio controllers **525** and **526** and microphone **510** to cancel out any unwanted echoes and feedback. Bridge **520** couples the user **501** to parties **502-504** over telephone system **500**. Party **502** is coupled to input audio controller **530a** (elements **420** and **425** of FIG. 4) and output audio controller **530b** (elements **430** and **435** of FIG. 4) which may disconnect (X), mute (O), attenuate (-), amplify (+) (shown in Figure as  $\pm OX$ ), or otherwise process audio characteristics of the signal in accordance with the user's settings. Each other party **503** and **504** is coupled to system **500** in a similar manner. A bridge **520** is utilized to conference parties **502-504** selectively among each other and/or to user **501**. Input signals to bridge **520** are combined into a single output signal to provide selective conferencing between parties **502-504** selectively among each other and/or user **501**. Bridge **520** may be part of the telephone unit, a switch and/or a third party proprietary device. Presently available hardware may be utilized to implement the features and functions of bridge **520**. User **501** may selectively establish the type of connection with parties **502-504**. Particularly, signals from parties **502-504** may be directly delivered to user **501** or may be delivered via bridge **520**. Similarly, signals to parties **502-504** may be directly delivered to parties **502-504** or may be delivered via bridge **520**.

User **501** may thereby selectively control various call parameters for each of the called parties using interface **400** of FIG. 4. These call parameters include, but are not limited to, input audio control for each telephone line, output audio control for each telephone line, overall volume control, mute control for each telephone line, and connection control between one telephone line and the other telephone lines. FIG. 6 illustrates one example where party **502** is a secret advisor capable of listening to the conversation between party **503** and user **501**. Party **502** may also speak to only user **501**. This situation may be implemented by coupling the output and input of party **503** to bridge **520**. Signaling from party **502** is directly delivered to user **501**. Signaling to party **502** is delivered from bridge **520**. User **501** is coupled to receive signals from bridge **520** and directly from party **502**. Output signals from user **501** are delivered to bridge **520**. Party **502** may thereby privately listen to the conversation between user **501** and party **503** and concurrently still speak to user **501** during the call. This call situation may also be established without bridge **520** as shown in FIG. 7. As shown in FIG. 8, party **502** may also be coupled such that it is only privately listening to the conversation between user **501** and party **503**. Similarly, as shown in FIG. 9, party **502** may also be coupled such that it is only speaking to user **501** while user **501** is engaged in a call with party **503**. As shown in FIG. 10, user **501** may have two simultaneous, non-conferenced calls to parties **502** and **503**, known as a dispatcher-type function. FIG. 11 shows an example where user **501** may monitor a plurality of parties **502-504**. FIG. 12



is an example where user **501** may broadcast a message to a plurality of parties **502–504**. These call situations are merely examples of the numerous types of call arrangements that may be established with the present invention. The bridge may also be implemented within a connection controller which may be in the form of a microprocessor to provide the control of the connection parameters to each of the parties as discussed herein. Other hardware and/or software means may also be implemented to perform the functions of the bridge.

FIG. 3 shows another exemplary user interface **300** of a multi-line telephone system in accordance with another preferred embodiment of the present invention. As shown, this user interface **300** is capable of connecting to five telephone lines. User interface **300** may be implemented within the multi-line telephone itself or as a separate component coupling the telephone lines with the multi-line telephone. User interface **300** includes a row of controls for each telephone line coupled to the telephone. Each row includes a line selection button **305**, an audio control **310**, and a mute button **315**. Line selection button **305** preferably allows the user to select which lines are to be conferenced. In accordance with the present invention, audio control **310** allows the user to selectively adjust the audio signal parameters received by the corresponding telephone line. Mute button **315** allows the user to mute the telephone line so that the associated calling party does not receive any voice signals. Those skilled in the art will appreciate that any number of user interfaces could be implemented and are meant to be within the spirit and scope of the present invention. For example, in the implementation of a multimedia conferencing system (such as that disclosed in U.S. Pat. No. 5,195,086), the user-interface may be in the form of a Windows-based Graphical User Interface (GUI).

In yet another embodiment, audio controller **115** of **215** (of FIG. 1 or 2) may be an intelligent controller capable of automatically adjusting the relative audio characteristics of the conferenced lines. In this embodiment, intelligent audio controller **115** or **215** may include a digital signal processor (DSP), a microprocessor or other circuitry appropriate to monitor the voice signals of each active line for background noise or music. Audio signal parameters of the telephone lines could thereby be adjusted to compensate for the unwanted noise. Additionally, or in the alternative, intelligent audio controller **115** or **215** may monitor the voice signals of each active telephone line to compare various audio characteristics. Intelligent audio controller **115** or **215** may thereby automatically adjust the audio signal parameters of each telephone lines such that the voice signals have relatively similar audio characteristics as perceived by the human ear.

Those skilled in the art will appreciate that the present invention may be implemented within any variety of communications systems where voice signaling is utilized. For example, the present invention may be implemented within any multi-media conferencing system to selectively control the voice signal amplitude of each of the conferenced callers. An example of such a multi-media system may be that disclosed in U.S. Pat. No. 5,195,086 entitled "Multiple Call Control Method in a Multimedia Conferencing System" and assigned to AT&T Bell Laboratories, incorporated herein by reference.

The present invention is provided by way of description of one embodiment. The principles of the invention may be extended to provide selective control of voice signals for any number of telecommunications related services such as Internet services, television/video/data conferencing ser-

vices and the like. The present invention may also be implemented within a private, local and/or long distance communications network. The scope of the invention should only be deemed limited by the claims which follow.

I claim:

1. A multi-line telephone system comprising:

(a) at least one coupling means to connect the multi-line telephone system to at least two telephone lines to receive and transmit signals associated with each of the telephone lines;

(b) a user interface associated with the multi-line telephone system to allow a user to selectively control at least one call connection parameter for each of at least two active telephone lines, wherein the call connection parameter for each active telephone call is selected from the group consisting of input audio control, output audio control, connection control from a first active telephone call to a second active telephone call, and connection control from the second active telephone call to the first active telephone call; and

(c) means for selectively controlling a parameter of the call connection to at least one active telephone call in response to an input from the user interface.

2. The multi-line telephone system of claim 1, wherein the multi-line telephone system is part of a multimedia system and at least one telephone call transmits video signals.

3. The multi-line telephone system of claim 1 wherein the multi-line telephone system is part of a multimedia system and at least one telephone call transmits video and data signals.

4. The multi-line telephone system of claim 1, wherein the input and output audio controls provide control of audio characteristics selected from the group consisting of peak volume, average volume, noise level, bass and treble.

5. In a multi-line telephone system, a method of selectively controlling at least one call connection parameter for each of at least two telephone calls comprising the steps of:

(a) engaging in a first telephone call with a first party wherein a first call connection parameter is established by the multi-line telephone system;

(b) engaging in a second telephone call with a second party wherein a second call connection parameter is established by the multi-line telephone system;

(c) connecting the first and second telephone calls to the multi-line telephone system; and

(d) selectively adjusting at least one of the first call connection parameters, wherein the first call connection parameter is selected from the group consisting of input audio control, output audio control, connection control from the first telephone call to the second telephone call, and connection control from the second telephone call to the first telephone call.

6. The method of claim 5, wherein the input and output audio controls provide control of audio characteristics selected from the group consisting of peak volume, average volume, noise level, bass and treble.

7. The method of claim 5, further comprising the step of:

(e) selectively adjusting at least one of the second call connection parameters, wherein the first call connection parameter is selected from the group consisting of input audio control, output audio control, connection control from the first telephone call to the second telephone call, and connection control from the second telephone call to the first telephone call.

8. The method of claim 7, wherein the input and output audio controls provide control of audio characteristics

selected from the group consisting of peak volume, average volume, noise level, bass and treble.

9. A multi-line telephone system comprising:

- (a) a telephone line receiver capable of being coupled to at least two telephone calls to receive signals associated with each of the telephone calls, the signals from each of the telephone calls having a corresponding audio characteristic, wherein the audio characteristic is selected from the group consisting of peak volume, average volume, noise level, bass and treble;
- (b) at least one call connection switch wherein the call connection switch is associated with at least one telephone calls to couple the associated telephone call to a user at the multi-line telephone system; and
- (c) at least one audio controller capable of selectively adjusting the audio characteristic of the signal associated with at least one of the telephone calls.

10. The multi-line telephone system of claim 9, wherein the audio controller is an intelligent audio controller.

11. The multi-line telephone system of claim 10, wherein the intelligent audio controller includes a microprocessor coupled to receive and process the signals and wherein the intelligent audio controller may responsively adjust the audio characteristic of the signal associated with at least one of the telephone calls.

12. The multi-line telephone system of claim 9, wherein the multi-line telephone system is part of a multimedia system and at least one telephone calls transmits video signals.

13. The multi-line telephone system of claim 9, wherein the multi-line telephone system is part of a multimedia system and at least one telephone calls transmits video and data signals.

14. In a multi-line telephone system, a method of selectively controlling an audio level of an incoming audio signal from a telephone call comprising the steps of:

- (a) engaging in a first telephone call with a first party wherein a first audio signal is received by the multi-line telephone system, the first audio signal having a first audio characteristic selected from the group consisting of peak volume, average volume, noise level, bass and treble;
- (b) engaging in a second telephone call with a second party wherein a second audio signal is received by the multi-line telephone system, the second audio signal having a second audio characteristic selected from the group consisting of peak volume, average volume, noise level, bass and treble;
- (c) connecting the first and second telephone calls such that a user at the multi-line telephone system may simultaneously receive the first and second audio signals from the first and second telephone calls; and
- (d) selectively adjusting the first audio characteristic of the audio signal from the first telephone call.

15. The method of claim 14, further comprising the step of:

- (e) selectively adjusting the second audio characteristic of the audio signal from the second telephone call.

16. The method of claim 14, wherein the step of selectively adjusting includes the steps of processing at least one of the first and second audio signals and responsively adjusting at least one of the first and second audio characteristics.

\* \* \* \* \*